

Centrifugal-Action Sand Separators

IHB



Advanced and patented LAKOS design offers proven performance with low pressure loss. Removes sand and grit; new exclusive features improve performance to remove 50% more of finer particles, offering maximum protection. Independently tested. Proven superior for today's demanding filtration requirements.

Trouble-free operation keeps water clean and concentrates separated sand

No screens or filter elements to clean or replace; no routine maintenance

No backwashing; zero water loss options

Low and steady pressure loss: 3-12 psi (0.2-0.8 bar)

Space-saving profile

Swirlex internal accelerating slots for optimum sand-removal performance; patented

Vortube for enhanced sand separation/collection; patented

Grooved inlet/outlet connections for easy installation; flange adapters available

In-line inlet/outlet configuration for simplified piping

Unishell construction for easy installation

ASME Code option available



Flow range:
285 - 4,350 U.S. gpm
(65 - 988 m³/hr) per unit

Maximum standard
pressure rating:
150 psi (10.3 bar)

ACCESSORIES



Visual Purge



Automatic Ball Valve

How It Works

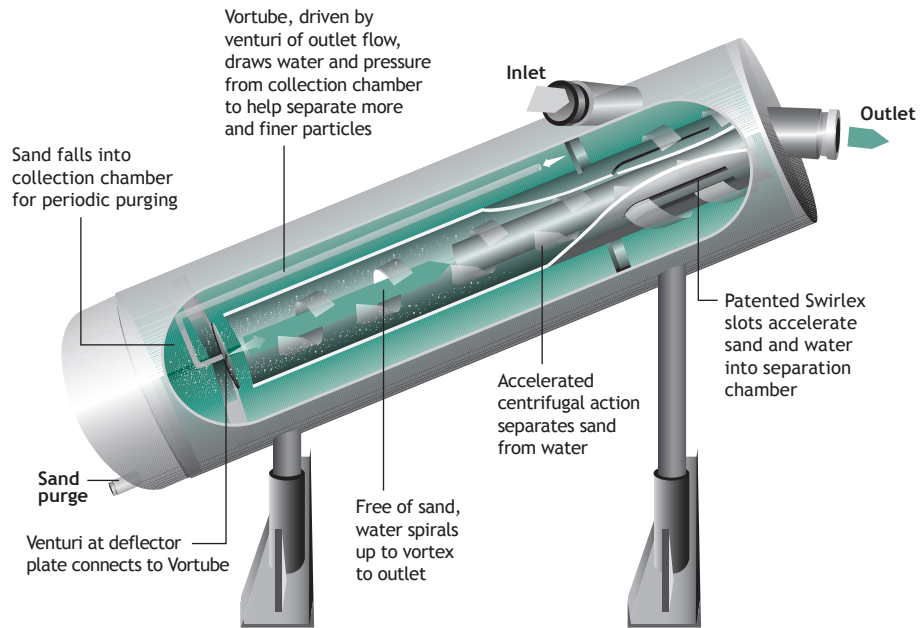

Installation Instructions

- 1 LAKOS IHB Separators are shipped on a wooden skid with the two support legs detached. A large ring, located on the unit's side, is provided for hoisting as necessary.
- 2 A suitable foundation is necessary to accommodate the separator's weight including water (see chart, page 3). Tie-down bolts are recommended in the base of the legs. Prior to installation, inspect the inlet, outlet and purge of each unit for foreign objects that may have entered the unit during shipping or storage.
- 3 Proper purge hardware is required to flush separated sand from the separator. This equipment should be installed before start-up.
- 4 Pipe connections to the inlet and outlet of LAKOS IHB Separator should be a straight run of at least five pipe diameters to minimize turbulence and optimize performance. *Pipe size is not a factor in selecting the proper model of a LAKOS Separator.* Rather, all LAKOS Separators operate within a prescribed flow range.
- 5 Use appropriate hardware to match inlet and outlet size. Grooved couplings are not included with the separator. Inlet pressure to the LAKOS Separator must be at least equal to or greater than the anticipated pressure loss through the separator, plus 15 psi (1.0 bar), plus the required downstream pressure.
- 6 LAKOS IHB Separators are typically installed on the discharge of a pumping system. Consult your LAKOS representative for suction side installation. No other pressure or power is required to operate a LAKOS Separator.
- 7 In a pressurized system (vs. open discharge), pressure gauges are recommended at both inlet and outlet to monitor pressure loss and proper system flow. If the separator is operated at open discharge, a valve is recommended at the outlet, set to create a backpressure of 5 psi (0.3 bar).
- 8 Winterizing is important if the separator is to remain idle in freezing temperatures. Drain water as necessary to avoid bursting due to water-ice expansion.

Maintenance/Purging

LAKOS IHB Separators must be purged regularly to remove the separated sand from the temporary collection chamber.

All purge hardware should be installed prior to any elbow or turns in the purge piping.

Avoid "uphill" purging, which can clog purge piping and hinder effective sand evacuation.

For best results, purging is recommended while the LAKOS Separator is in operation, utilizing system pressure to enhance sand evacuation.

LAKOS offers a durable, reliable automatic purging system to eliminate routine maintenance. Frequency of purging and duration of purging are both programmable to accommodate the specific needs of virtually any application.

Be sure to include an isolation valve prior to the automatic valve (available from LAKOS at an additional cost) to facilitate servicing of the automatic valve without system shut down.

IHB

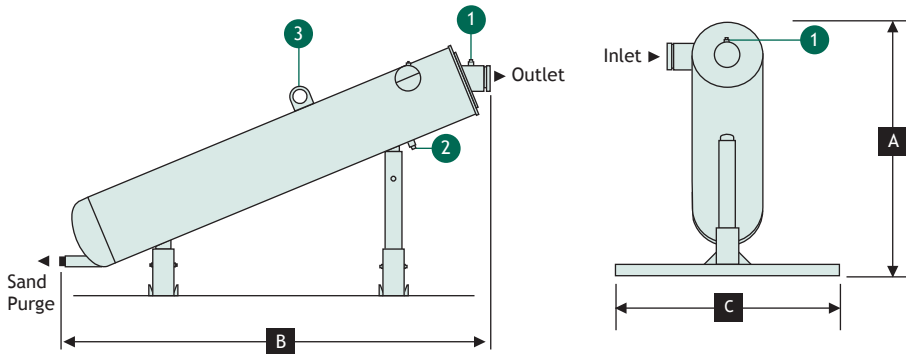

Dimensions

| Model | A | | B | | C | |
|----------|--------|------|--------|------|----|------|
| | in | mm | in | mm | in | mm |
| IHB-0285 | 45 | 1143 | 78-1/4 | 1994 | 40 | 1016 |
| IHB-0450 | 52-1/2 | 1333 | 96-1/4 | 2445 | 40 | 1016 |
| IHB-0500 | 52-1/2 | 1333 | 96-1/4 | 2445 | 40 | 1016 |
| IHB-0810 | 61 | 1549 | 108 | 2743 | 40 | 1016 |
| IHB-1275 | 72-1/2 | 1841 | 130 | 3302 | 40 | 1016 |
| IHB-1950 | 79-1/4 | 2013 | 142 | 3607 | 40 | 1016 |

Specifications

| Model | Flow Range | | Inlet/Outlet Grooved Coupling | Purge Size male N.P.T. | Collection Chamber Capacity | | Weight | | Weight with Water | |
|----------|------------|--------------------|-------------------------------|------------------------|-----------------------------|--------|--------|-----|-------------------|------|
| | U.S. gpm | m ³ /hr | | | gal | liters | lbs. | kg | lbs. | kg |
| IHB-0285 | 285-525 | 65-120 | 4" | 1-1/2" | 2.1 | 7.9 | 476 | 216 | 786 | 357 |
| IHB-0450 | 450-825 | 102-187 | 6" | 1-1/2" | 2.8 | 10.6 | 699 | 318 | 1163 | 529 |
| IHB-0500 | 500-1100 | 114-250 | 6" | 1-1/2" | 2.8 | 10.6 | 703 | 320 | 1167 | 531 |
| IHB-0810 | 810-1670 | 184-379 | 8" | 1-1/2" | 6.2 | 23.5 | 966 | 439 | 1856 | 844 |
| IHB-1275 | 1275-3100 | 290-704 | 10" | 2" | 11.5 | 43.5 | 1344 | 611 | 2960 | 1346 |
| IHB-1950 | 1950-4350 | 443-988 | 12" | 2" | 15 | 56.8 | 1795 | 816 | 3933 | 1788 |

Flow vs. Pressure Loss

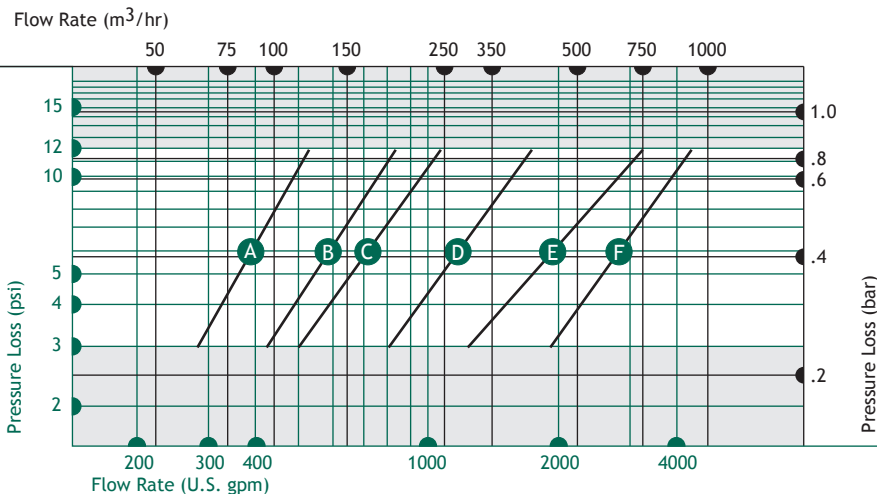

1 Inlet/Outlet Pressure Gauge Taps
1/4-inch NPT female; required at both inlet and outlet for proper flow verification

2 Inspection/Drain Plug
1/2-inch NPT female; provides access to upper chamber for inspection of slot area; also allows for draining the upper chamber if necessary

3 Lifting Ring
For installation purposes

Note:
Maximum particle size: 3/8-inch (9 mm)

Also available with ANSI, DIN or JIS adapter flanges

Consult factory for higher flow rates.

- A IHB-0285
- B IHB-0450
- C IHB-0500
- D IHB-0810
- E IHB-1275
- F IHB-1950

Additional LAKOS Solutions

Limited Warranty

All products manufactured and marketed by this corporation are warranted to be free of defects in material or workmanship for a period of at least one year from date of delivery. Extended warranty coverage applies as follows:

All LAKOS Separators: Five year warranty

All other components: 12 months from date of installation; if installed 6 months or more after ship date, warranty shall be a maximum of 18 months from ship date.

If a fault develops, notify us, giving a complete description of the alleged malfunction. Include the model number(s), date of delivery and operating conditions of subject product(s). We will subsequently review this information and, at our option, supply you with either servicing data or shipping instruction and returned materials authorization. Upon prepaid receipt of subject product(s) at the instructed destination, we will then either repair or replace such product(s), at our option, and if determined to be a warranted defect, we will perform such necessary product repairs or replace such product(s) at our expense.

This limited warranty does not cover any products, damages or injuries resulting from misuse, neglect, normal expected wear, chemically-caused corrosion, improper installation or operation contrary to factory recommendation. Nor does it cover equipment that has been modified, tampered with or altered without authorization.

No other extended liabilities are stated or implied and this warranty in no event covers incidental or consequential damages, injuries or costs resulting from any such defective product(s).

Lakos Separators are manufactured and sold under one or more of the following U.S. Patents: 5,320,747; 5,338,341; 5,368,735; 5,425,876; 5,571,416; 5,578,203; 5,622,545; 5,653,874; 5,894,995; 6,090,276; 6,143,175; 6,167,960; 6,202,543; 7,000,782; 7,032,760 and corresponding foreign patents, other U.S. and foreign patents pending.

1365 North Clovis Avenue
Fresno, California 93727 USA
Telephone: (559) 255-1601
FAX: (559) 255-8093
www.lakos.com
info@lakos.com

LAKOS Backwash Reduction System (BRS) is available as a specified option and is easily retrofitted with all LAKOS sand filter systems. It reduces sand filter backwashing cycles by 50% or more, reducing water loss and maintaining optimum flow and pressure to the irrigation system.

As a pre-filter to your sand filter system, the Backwash Reduction System removes troublesome sand and settleable particles to dramatically reduce the contaminant load on the sand media surface. Centrifugal action performance and easily automated purging provides a maintenance-free alternative to wasteful backwashing. It is effective and affordable.



BRS- Backwash Reduction System

The Complete Family of LAKOS Irrigation and Landscape Filtration Solutions



Refer to literature LS-848 at www.LAKOS.com
for more information

LAKOS
Separators and Filtration Solutions